

auto electrical parts

Technical Information Sheet

Part No. 0-505-25

Red reflector with back frame. Acrylic lens. 2 x 4mm screw holes. E Marked.



Technical Drawing (not to scale)

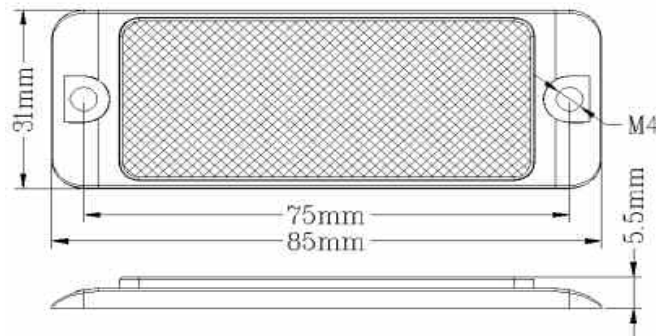

Specification

Type	Reflector
Colour	Red
Material	Acrylic
Dimensions	As above
Certifications	E Marked

The information contained in this document is correct to the best of our knowledge at the time of printing. However, specifications may change at any time without notice.